



Date: _____

Item No.: _____

Project No.: _____

Specifications

Description

Berg's granita/slushy machines are perfect for any establishment wanting to offer cold or frozen drinks. It's compact and streamlined design allows it to fit even in the smallest of areas. The powerful 1/3 HP motor cools the product inside quickly. The continuous agitator system and stainless steel cooling cylinder keeps the product inside the clear polycarbonate hopper moving and fresh while in use. The non-drip tap is easy to use and prevents product leakage when serving. Nighttime running feature is great for conserving energy after hours of operation. LED lighting built into the top panel helps brighten the product inside the hopper. 115V/60Hz. 6' power cord with a NEMA 5-15P plug. This unit is CE Certified and backed by Berg's 1 year replace or repair warranty.

Construction

- Clear 3 gallon polycarbonate hoppers with lighted top panel
- Frame is constructed of stainless steel and durable high impact plastic
- Non-drip tap mechanism is easy to use and prevents leakage
- Removable drip tray with float indicator for easy cleaning
- Non-slip feet for stability

Cooling and Agitator System

- Refrigeration system uses R-404A refrigerant
- Adjustable digital thermostat with cold drink/slushy settings
- Continuous agitator system keeps product fresh and mixed while in use
- Stainless steel cooling cylinder keeps the product cold/frozen
- Nighttime running feature helps to conserve energy

Electrical

- Separate on/off switches for power and agitator(s) gives you complete control of the unit's operation
- LED lighting built into the top panel helps illuminate the product inside the hopper
- 115V/60Hz electrical connection
- 6' power cord with NEMA 5-15 plug

Certifications/Approvals



Granita/Frozen Beverage Dispensers

Models:

- SGM-1
- SGM-2



SGM-1



SGM-2

Warranty: This product is protected by a 1 year limited warranty. Should your product fail under normal use it will be repaired or replaced up to one year from date of purchase.





Date: _____

Item No.: _____



Project No.: _____

Granita/Frozen Beverage Dispensers - SGM-1 and SGM-2

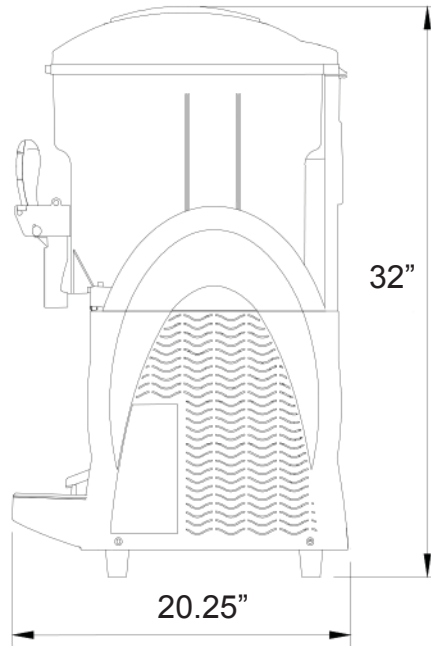
Plan View



Specifications

Item Number	Description	Total Capacity	Volts	Wattage	Amps	NEMA Plug
SGM-1	Single Hopper Granita/Slushy Dispenser	3 Gallons	115V	500W	4.3	5-15P 
SGM-2	Double Hopper Granita/Slushy Dispenser	6 Gallons	115V	960W	8.3	5-15P 

Item Number	Item Dimensions	Refrigerant
SGM-1	10.5"W x 20.25"D x 32"H	R-404A
SGM-2	18.5"W x 20.25"D x 32"H	R-404A

Shipping Info

Item Number	Box Dimensions	Gross Weight	Net Weight
SGM-1	13.75"W x 23"D x 39"H	84 lbs	70.5 lbs
SGM-2	21.5"W x 23"D x 39"H	145 lbs	132 lbs

Specifications subject to change without notice.