



# Refrigerated Sandwich Prep Tables

## One, Two and Three Door

Service / Warranty: 888-828-5535



**MODELS:** BERS27  
BERS48  
BERS60  
BERS72

### FEATURES:

- Stainless Steel Exterior & Interior
- Rear Mount Compressor with environmentally friendly R290 refrigerant
- Dixell Digital Controller
- Maintains temperatures between 33°F -40°F
- Pre-installed 1/6 size food pans
- 10" cutting board
- Recessed Door Handle(s)
- Self-Closing door(s) with stay open feature
- Magnetic Door Gasket(s) standard for positive door seal
- One (1) Pre-Installed shelf per section
- Pre-Installed Casters

### DIMENSIONS:

	Width	Depth	Height	Net Weight
BERS27	27 <sup>1/2</sup>	× 30	× 44 <sup>1/4</sup>	159
BERS48	48 <sup>1/4</sup>	× 30	× 44 <sup>1/4</sup>	231
BERS60	60 <sup>1/4</sup>	× 30	× 44 <sup>1/4</sup>	271
BERS72	72 <sup>11/16</sup>	× 30	× 44 <sup>1/4</sup>	317

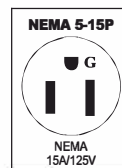



# Refrigerated Sandwich Prep Tables

## One, Two and Three Door

Service / Warranty: 888-828-5535

### SPECIFICATIONS

Model	Doors	Shelves	Cu.Ft	Exterior Dimensions (W x D x H)	Casters	Weight(LBS)	Voltage	HP	Amps	Refrigerant
BERS27	1	1	7.15	27 <sup>1/2</sup> × 30 × 44 <sup>1/4</sup>	5 inch	196	115/60/1	1/6	2.3	R290
BERS48	2	2	13.38	48 <sup>1/4</sup> × 30 × 44 <sup>1/4</sup>	5 inch	276	115/60/1	1/6	2.3	R290
BERS60	2	2	17.2	60 <sup>1/4</sup> × 30 × 44 <sup>1/4</sup>	5 inch	320	115/60/1	1/5	2.8	R290
BERS72	3	3	21.13	72 <sup>11/16</sup> × 30 × 44 <sup>1/4</sup>	5 inch	379	115/60/1	1/5	2.8	R290

### LINE DRAWINGS

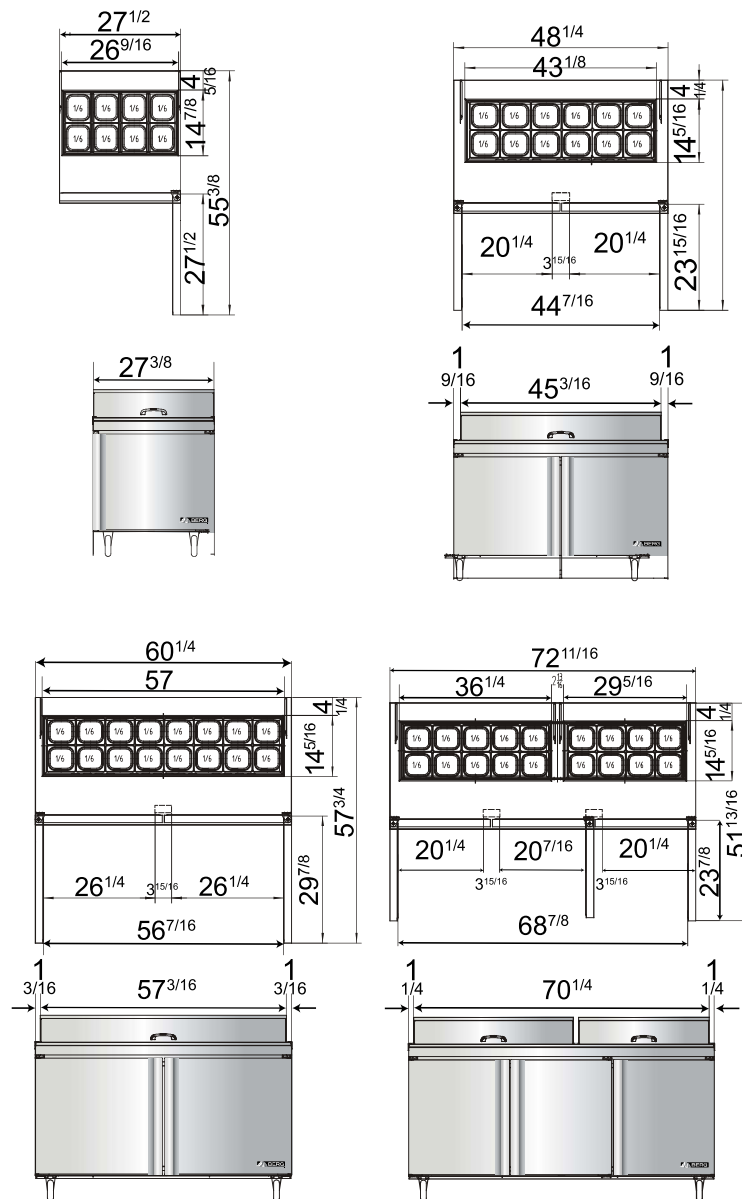

### Side View

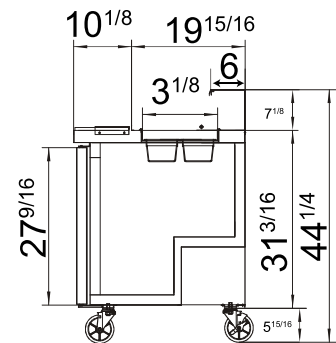

### Temperature Control



### Epoxy Shelves



### Casters



### Rear Grate

